

30" Gas Cooktop with UltraHeat™ Burner

- Integrated, Pro-Style Design
- 5 Sealed Burners
- Dual Stacked UltraHeat™ 19,000 BTU Center Burner (900 BTU Simmer)
- 3 Heavy-Duty Continuous Cast Iron Grates (Dishwasher Safe)
- Red LED Backlit Metal Knobs
- Griddle Plate Included



COLOR AVAILABILITY

- LSCG307ST – Stainless Steel

COOKTOP FEATURES

Number of Sealed Burners	5
Burner BTU (NG / LP)	
Left Front	9,100 / 9,100
Left Rear	9,100 / 9,100
Center	19,000 / 15,000 (UltraHeat™)
Right Front	12,000 / 9,500
Right Rear	5,000 / 5,000
Griddle Plate	Yes
Continuous Grates	Yes
Dishwasher Safe Grates	Yes

CONTROLS

Cooktop Control Type	Front, Metal Knob Control
Knob Lighting	Yes (Red LED)

CONVENIENCE

ADA Compliant	No
---------------	----

SMART FEATURES

Wi-Fi Enabled	No
ThinQ®	No

FINISHES AND APPEARANCE

Cooktop Surface	Stainless Steel
Knobs	Stainless Steel Appearance

TECHNICAL SPECS

Fuel Type	NG / LP
Required Power Supply	120V, 60 Hz
Minimum Circuit Rating	15 Amp
Power Cord Type	3-Prong Cord Attached to Unit
Gas Supply Location	See Installation Diagram

INCLUDED ACCESSORIES

Griddle Plate

DIMENSIONS / CLEARANCES / WEIGHTS

Product Dimensions (W x H x D)	30" x 3 3/4" x 21 11/16"
Cut-out Dimensions (W x H x D)	28 1/2" x 3 9/16" x 19 11/16"
Minimum Spacing to Back Wall	2 3/4"
Minimum Spacing to Side Walls	11"
Minimum Front Countertop Clearance	1 5/8"
Carton Dimensions (W x H x D)	34 9/16" x 10 1/2" x 25 31/32"
Approx. Weight (Product / Carton)	45 lbs. / 54 lbs.

LIMITED WARRANTY

Parts and Labor	2 Years
-----------------	---------

DIMENSIONS / CLEARANCES

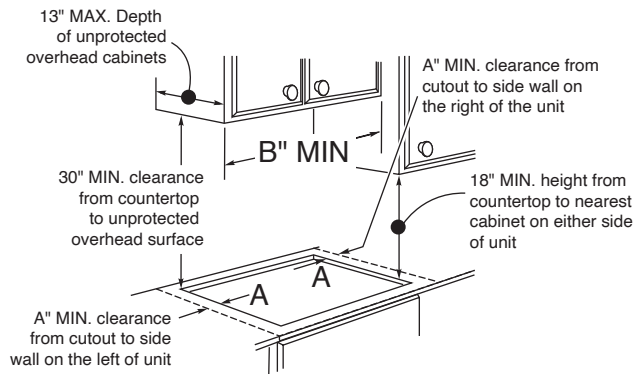
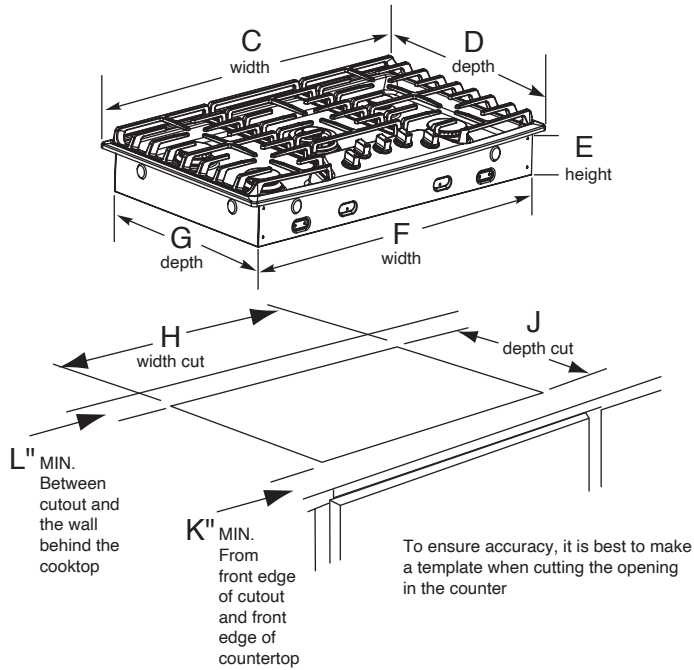

DIMENSIONS / CLEARANCES

A	11 13/16" (300 mm)
B	30" (762 mm)
C	30" (762 mm)
D	21 11/16" (550.9 mm)
E	3 3/4" (95.3 mm)
F	28 1/4" (717.6 mm)
G	19 3/8" (492.1 mm)
H	28 1/2" (723.9 mm)
J	19 11/16" (500.1 mm)
K	1 5/8" (41.3 mm)
L	2 3/4" (69.9 mm)

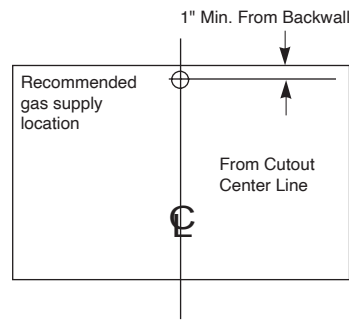

INSTALLATION NOTES

- Provide enough clearance between the cooktop and adjacent combustible surfaces. These dimensions must be met for safe use of your cooktop.
- Make sure wall coverings, countertop and cabinets around cooktop can withstand heat (up to 200°F) generated by cooktop.
- The cooktop may be placed with 2 3/4" clearance to the back wall.
- The location of the electrical outlet and pipe opening may be adjusted to meet specific requirements.